

XP12v2 Retrofit Instructions: MODEL NO. XP12v2RBKT

Product description:

The **XP12v2 Retrofit Bracket** is an adapter for in-wall nearly flush retrofit installation of a XP12v2 touch screen.

The **XP12v2 Retrofit Bracket** securely mounts the XP12v2 touch screen while allowing easy insertion, removal and operation.

Key features and benefits:

- Nearly flush with the wall (0.16 in. [4mm] thick on-wall bezel).
- Wall mount may be mounted in any orientation.
- Allows easy insertion and removal of the touch screen.
- Bezel attaches magnetically to the retrofit wall mount base.

Key properties:

- Dimensions: (W/H/D):
15.53 in. (394.4mm) x 11.11 in. (282.3mm)
x 1.66 in. (41mm)
- Weight: 4.84 lbs. (2.2kg)
- Material: Moisture resistant MDF

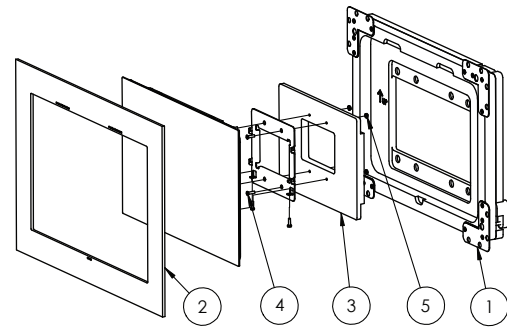

Adapter kit contains:

1. One wall mount base
2. One bezel
3. One touch panel adapter
4. Four M3x12 screws
5. Four M3 nuts

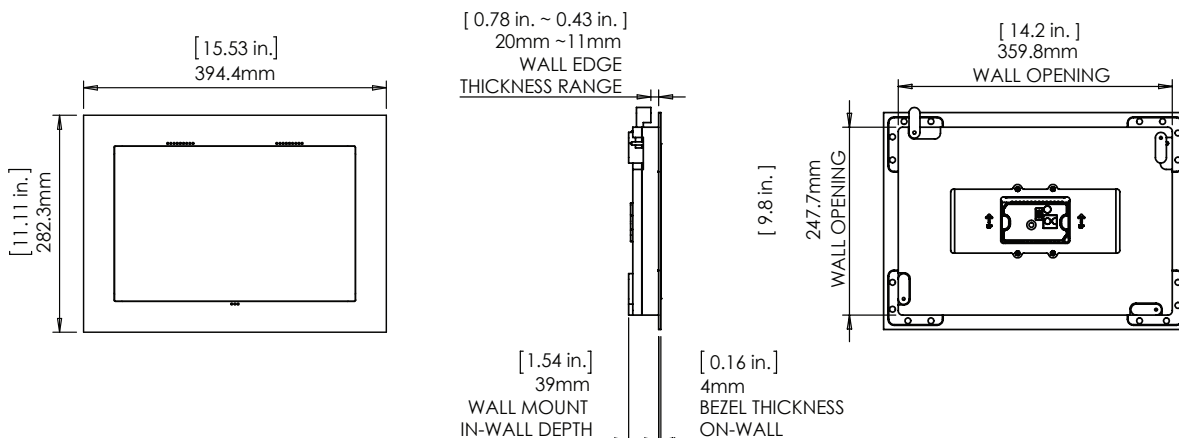
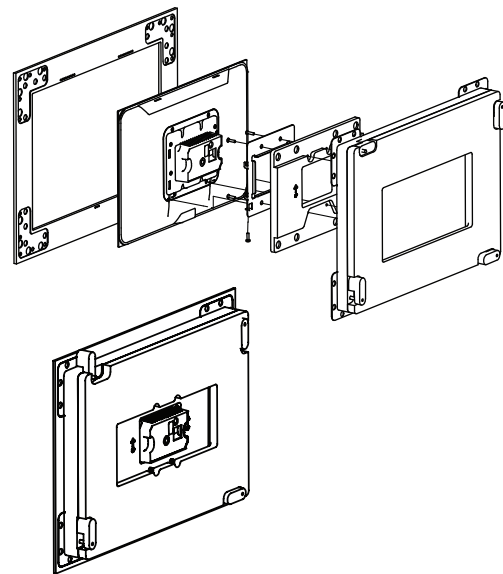
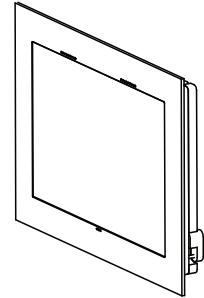

MODEL NO. XP12v2RBKT

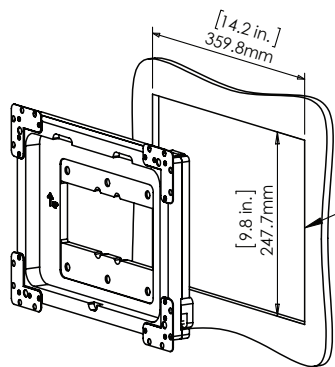

1. CUT OPENING
2. ROUTE NECESSARY CABLES

3. INSERT WALL MOUNT BASE
4. GENTLY SCREW CLOCKWISE 4 RETENTION SCREWS UNTIL CAM LATCHES RETAIN THE UNIT.

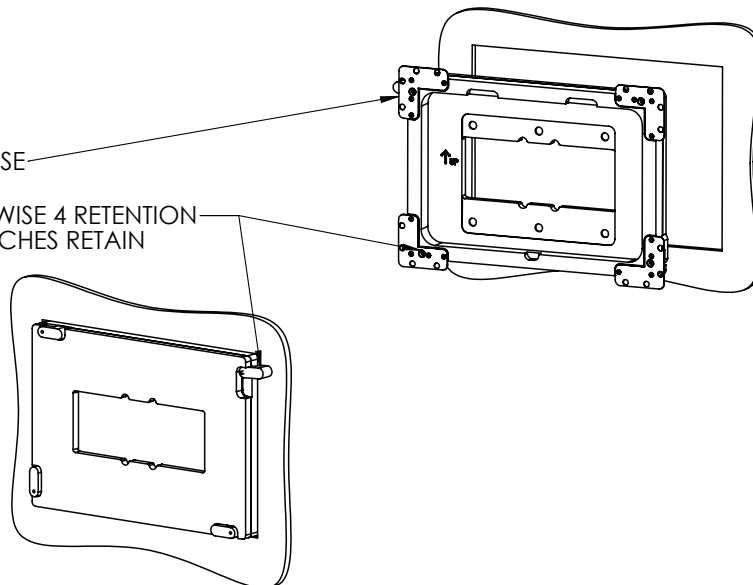

5. ASSEMBLE THE TOUCH PANEL ADAPTOR
6. ATTACH TOUCH SCREEN (MAGNETICALLY)

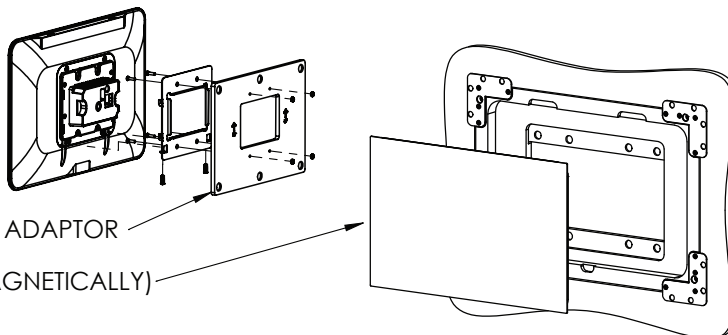

7. ATTACH THE BEZEL (MAGNETICALLY)

